

# M811 SERIES

## DC/DC POWER SUPPLY



### PRODUCT HIGHLIGHTS

- MINIATURE, HIGH DENSITY
- EIGHT OUTPUTS
- UP TO 145 W
- DC/DC POWER SUPPLY

## Applications

Military, Ruggedized, Telecom,  
Industrial Power Supply

## Special Features

- Miniature size
- High efficiency
- Wide input range
- Up to 9.9 W/in<sup>3</sup>
- Input / Output isolation
- Fixed switching frequency (250 kHz)
- TTL logic enable
- EMI filters included
- Indefinite short-circuit protection with auto-recovery
- Input over-voltage shutdown with auto-recovery
- Over-temperature shutdown with auto-recovery

## Environmental Conditions

Designed to meet MIL-STD-810D

### Temperature:

Operating: -55 °C to +85 °C (at baseplate)

Storage: -55 °C to +125 °C

## Reliability

150,000 hours, calculated IAW MIL-HDBK-217F Notice 2  
at +85 °C baseplate, Ground Fix conditions.

## Electrical Specifications

### DC INPUT

DC Input range: 18 to 48 V<sub>DC</sub> Input transient protection:

All models meet or exceed (no damage)

MIL-STD-1275A (100 V for 50 ms) and

MIL-STD-704A, MIL-STD-704D (80 V for 0.1 s)

Over-voltage shutdown with auto-recovery Efficiency: Up  
to 82%

### EMC:

Designed to meet MIL-STD-461F\*

CE101, CE102, CS101, CS114, CS115, CS116, RE101,

RE102, RS101, RS103

### Isolation:

Input to Output: 200 V<sub>DC</sub>

Input to Case: 200 V<sub>DC</sub> **DC OUTPUT (floating)** Line/Load

### regulation:

Less than 2% (no load to full load, -55 °C to  
+85 °C)

Ripple and Noise: 50 mV<sub>p-p</sub>, typical (max. 1%) Current

limiting (Hiccup):

Continuous protection for unlimited time Over-voltage

protection:

Passive transorb on output.

Over-temperature protection:

Shutdown if baseplate temperature rises above

+100 °C ± 5 °C. Automatic recovery when

baseplate cools down to below +90 °C ± 5 °C. Isolation:

Output to Case: 100 V<sub>DC</sub>

\*EMC compliance when tested with 5 H LISNs, shielded harness and static resistive load.

**M811 SERIES DC/DC POWER SUPPLY**

*Operational Block Diagram*

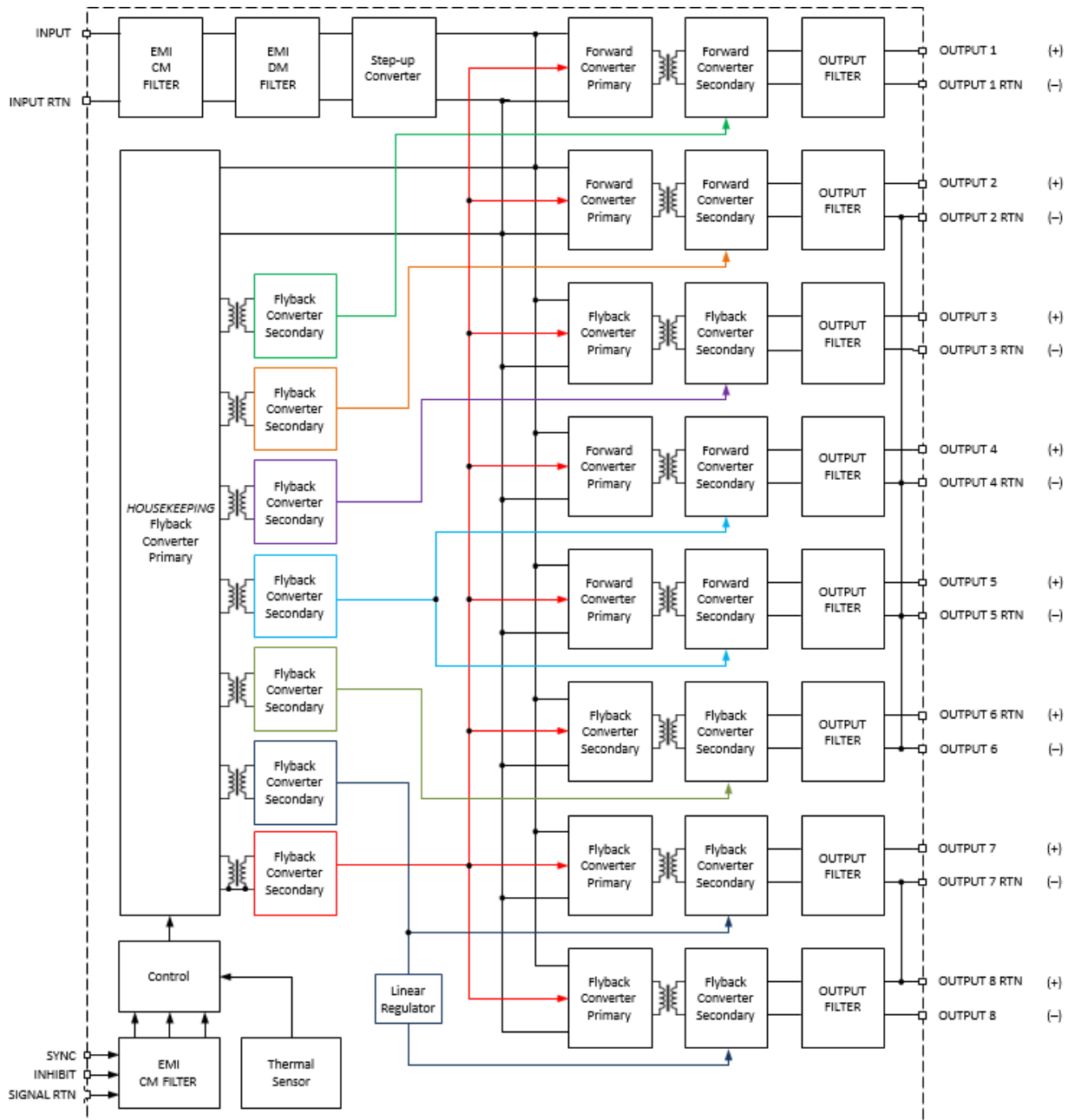

**Outputs Configuration Range**

Output #	Voltage Range	Current Range	Power Range
1	2.5 to 28 V <sub>DC</sub>	0 to 3 A	0 to 40 W
2	1.5 to 28 V <sub>DC</sub>	0 to 4 A	0 to 40 W
3	2.5 to 28 V <sub>DC</sub>	0 to 3 A	0 to 20 W
4	2.5 to 28 V <sub>DC</sub>	0 to 5 A	0 to 30 W
5	2.5 to 28 V <sub>DC</sub>	0 to 8 A	0 to 30 W
6	1.25 to 28 V <sub>DC</sub>	0 to 5 A	0 to 15 W
7	2.5 to 28 V <sub>DC</sub>	0 to 2.5 A	0 to 15 W
8	-2.5 to -28 V <sub>DC</sub>	0 to 2.5 A	0 to 15 W
<b>Total</b>			0 to 145 W

**Outputs Isolation (Ground RTN groups)**

- All outputs are isolated form the input.
- Outputs are separated into the following four galvanically isolated groups:
  - Group A: Output #1
  - Group B: Output #2, #4, #5 and #6
  - Group C: Output #3
  - Group D: Outputs #7 and #8

## M811 SERIES DC/DC POWER SUPPLY

### Pin Assignment

**Connector type:** M55302/61-A36 or eq.

**Mating connector type:** M55302/62-A36M (solder cup termination) or M55302/66-32M (#22 AWG crimp termination) or eq.

Pin #	Function	P		Pin #	Function	P		Pin #	Function	P	
1	INPUT	+	●	13	OUT 1	+	●	25	OUT 5	+	●
2	INPUT	+	●	14	OUT 2	+	●	26	2,4,5,6 RTN	-	●
3	INPUT RTN	-	●	15	INHIBIT	+	●	27	2,4,5,6 RTN	-	●
4	INPUT RTN	-	●	16	OUT 8	-	●	28	2,4,5,6 RTN	-	●
5	2,4,5,6 RTN	-	●	17	OUT 7,8 RTN		●	29	OUT 4	+	●
6	OUT 6	+	●	18	OUT 7	+	●	30	CHASSIS		●
7	OUT 5	+	●	19	INPUT	+	●	31	OUT 2	+	●
8	OUT 5	+	●	20	INPUT	+	●	32	SIGNAL RTN	-	●
9	2,4,5,6 RTN	-	●	21	INPUT RTN	-	●	33	SYNC	+	●
10	2,4,5,6 RTN	-	●	22	INPUT RTN	-	●	34	OUT 7,8 RTN		●
11	OUT 4	+	●	23	2,4,5,6 RTN	-	●	35	OUT 3	+	●
12	OUT 1 RTN	-	○	24	OUT 6	+	●	36	OUT 3 RTN	-	○

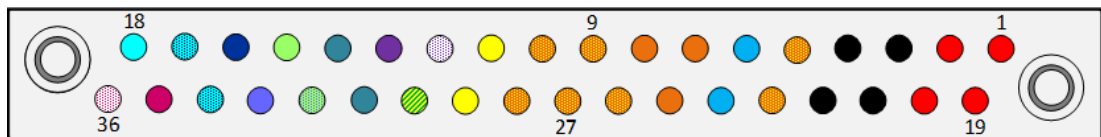

### ***Signals Description***

#### **INHIBIT** (pin 31)

The ***INHIBIT*** signal is used to turn the power supply ON and OFF. TTL “1” or OPEN – Power supply active (output turned on).

TTL “0” or SHORT to ***SIGNAL RTN*** – Power supply inhibited (output turned off). If this function is not required, leave this pin unconnected.

This signal is referenced to ***SIGNAL RTN*** (pin 32)

#### **SYNC** (pin 33)

The ***SYNC*** signal is used to synchronize the power supply's switching frequency to system's clock. If this function is not required, leave this pin unconnected - the power supply will use its internal clock.

External clock frequency can be between 240 kHz to 260 kHz, with duty cycle of 40% to 60%. Valid clock voltage level is between 5 to 12 V.

This signal is referenced to ***SIGNAL RTN*** (pin 32)

#### **SIGNAL RTN** (pin 32)

Both ***INHIBIT*** and ***SYNC*** signals are referenced to this pin. This pin is referenced to ***INPUT TN*** (pins 3, 4, 21 and 22).

**M811 SERIES DC/DC POWER SUPPLY**

**Outline Drawin**

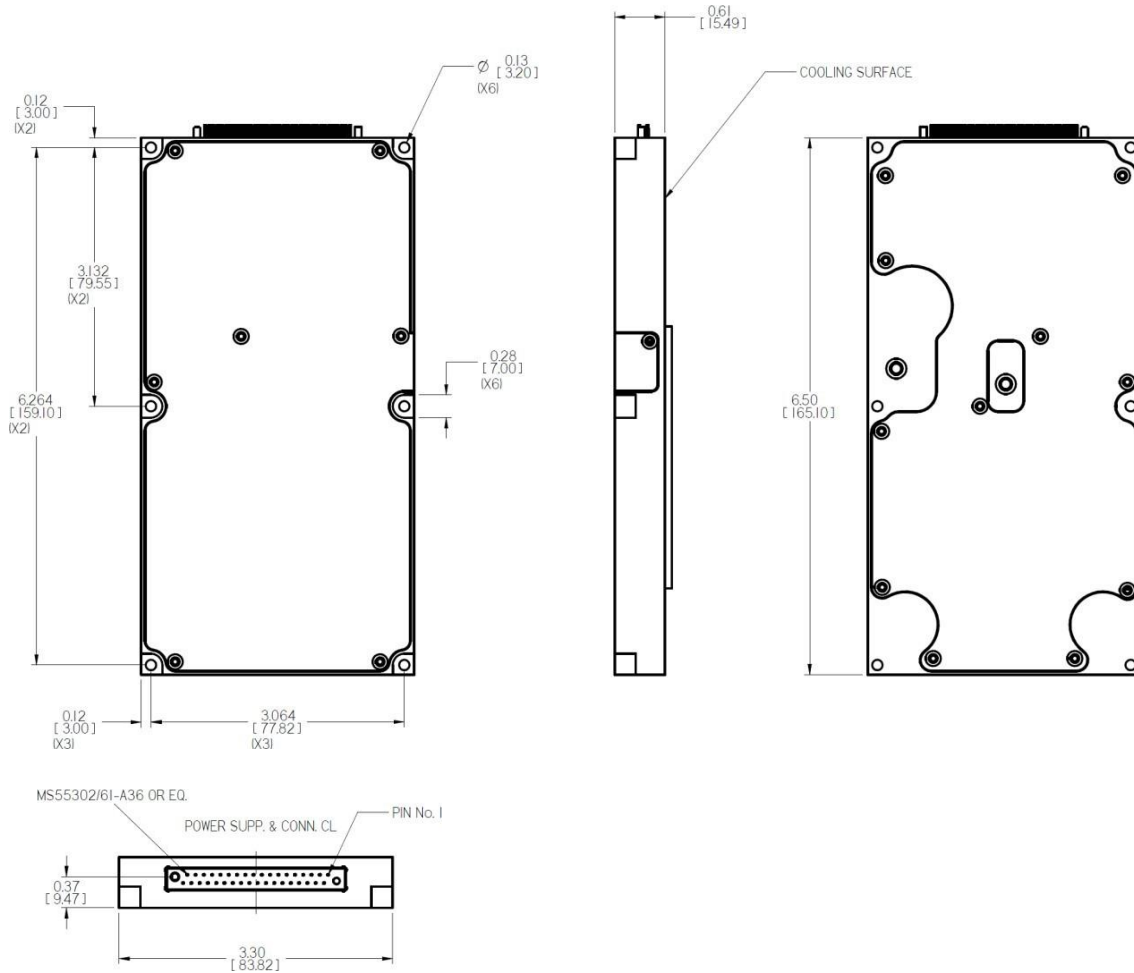

**Notes**

1. Dimensions are in inches [mm]
2. Tolerance is:  
.XX  $\pm$ .02 in  
.XXX  $\pm$ .01 in
3. Weight: Approx. 14 oz [400]

**Heat Dissipation Surface Area**

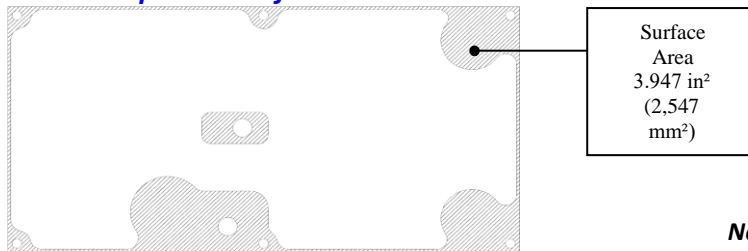

**Note: Specifications are subject to change without prior notice by the manufacturer**