

# M6201 SERIES

*DC/DC POWER SUPPLY*



## PRODUCT HIGHLIGHTS

- HIGH EFFICIENCY
- HIGH VOLTAGE
- SINGLE OUTPUT
- DC/DC POWER SUPPLY
- UP TO 200 W

## Applications

Military (Airborne, ground-fix, shipboard), Ruggedized, Telecom, Industrial

## Special Features

- High efficiency
- Wide input voltage range
- Input / Output isolation
- Remote sense
- Remote inhibit (On/Off)
- Fixed switching freq. (250kHz)
- External sync. capability
- EMI filters included
- Inrush current limiter circuit
- Indefinite short circuit protection with auto-recovery
- Over-voltage shutdown with auto-recovery
- Over temperature shutdown with auto-recovery

## Electrical Specifications

### DC Input

Voltage range: 200 to 350V<sub>DC</sub>

### DC Output

Voltage range: 1.8 to 60V<sub>DC</sub>

Current range: 0 to 36A

Power range: 0 to 200W

### Isolation

Input to Output: 500V<sub>DC</sub>

Input to Case: 500V<sub>DC</sub>

Output to Case: 100V<sub>DC</sub>

### Output Voltage Regulation

Better than ±1% (no load to full load, -55°C to +85°C and over

input voltage range).

### Efficiency

Typical: 88-90% (full load, nominal line voltage,

room temperature)

### EMC

Designed to meet\* MIL-STD-461F:

CE101, CE102, CS101, CS114, CS115, RE101, RE102, RS101, RS103

### Ripple and Noise

Better than 50mV<sub>p-p</sub>, typical (max. 1%) without external capacitance. When connected to system capacitance ripple drops significantly.

### Transient Over-and-undershoot

Output resistance at load change of 50% to 100% is 30 to 200mΩ (depending on output voltage).

Output back to steady stated within 300 to 50 μs.

### Turn on Transient

No voltage overshoot during power on.

\*EMC compliance achieved when tested with 5 μH LISNs, shielded harness and static resistive load.

## Protections\*

### Input

- **Inrush Current Limiter**  
Peak value of up to 5 times maximum input current for inrush currents lasting over 50 $\mu$ s.
- **Under-Voltage Lock-Out**  
Output shuts down when input voltage is below 180  $\pm$ 20V<sub>DC</sub>
- **Over-Voltage Lock-Out**  
Output shuts down if input voltage is above 370  $\pm$ 10V<sub>DC</sub>

### Output

- **Active Over-Voltage Protection**  
Internal control protects unit (no damage) 110%  $\pm$ 5% of nominal voltage.
- **Passive Over-Voltage Protection**  
Transorb on output, selected at 120%  $\pm$ 10% of nominal voltage.
- **Current Limiting (Hiccup)**  
Indefinite protection. Threshold set at 120%  $\pm$ 15% of nominal current.

### General

- **Over-Temperature Protection**  
Unit shuts down if baseplate's temperature rises above +105 $^{\circ}$ C  $\pm$ 5 $^{\circ}$ C. Unit automatically recovers when baseplate's temperature falls below +95 $^{\circ}$ C  $\pm$ 5 $^{\circ}$ C.

## Environmental Conditions

Designed to Meet MIL-STD-810F

### Temperature

Operating: -55 $^{\circ}$ C to +85 $^{\circ}$ C (at baseplate)  
Storage: -55 $^{\circ}$ C to +125 $^{\circ}$ C

### Altitude

Method 500.4  
Procedure I: Up to 70 000ft.  
Procedure II: Up to 20000ft.

### Salt Fog

Method 509.4

### Humidity

Method 507.4  
Procedure I  
Up to 95% RH

### Vibration (random)

Method 514.5  
Category 4 - General minimum integrity exposure  
IAW Figure 514.5C-17  
1 hour per axis.

### Shock

Method 516.5  
Procedure I  
30g, 11ms terminal peak saw-tooth,

## Reliability

150,000 hours, calculated IAW MIL-HDBK-217F Notice 2 at +85 $^{\circ}$ C baseplate, Ground fixed conditions.

## Environmental Stress Screening (ESS)

Including random vibration and thermal cycles is also available. **Please consult factory for details.**

\* Thresholds and protections can be modified / removed – please consult factory.

## Pin Assignment †

Connector type: M24308/24-75F or eq.

Mates with: M24308/2-13F or eq.

Pin No.	Function	P		Pin No.	Function	P		Pin No.	Function	P	
1	OUT	+	●	16	OUT	+	●	31	OUT	+	●
2	OUT	+	●	17	OUT	+	●	32	OUT	+	●
3	OUT	+	●	18	OUT	+	●	33	OUT	+	●
4	OUT	+	●	19	OUT	+	●	34	OUT	+	●
5	OUT RTN	-	●	20	OUT RTN	-	●	35	OUT RTN	-	●
6	OUT RTN	-	●	21	OUT RTN	-	●	36	OUT RTN	-	●
7	OUT RTN	-	●	22	OUT RTN	-	●	37	OUT RTN	-	●
8	OUT RTN	-	●	23	OUT RTN	-	●	38	OUT RTN	-	●
9	SENSE RTN	-	●	24	N.C.			39	N.C.		
10	INHIBIT	+	●	25	SENSE	+	●	40	N.C.		
11	SYNC IN	+	●	26	SIGNAL RTN	-	●	41	N.C.		
12	N.C.			27	N.C.			42	IN RTN	-	●
13	IN RTN	-	●	28	IN RTN	-	●	43	N.C.		
14	N.C.			29	N.C.			44	IN	+	●
15	IN	+	●	30	IN	+	●				

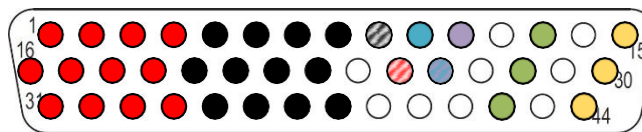

† All pins with identical function/designation should be connected together for optimal performance.

## Functions and Signals

### INHIBIT

The **INHIBIT** signal is used to turn the power supply ON and OFF.

To turn the power supply OFF, apply a TTL “0” signal or SHORT to **SIGNAL RTN**.

To turn the power supply ON, apply a TTL “1” signal or leave this pin OPEN. If not used (always ON), leave this pin OPEN.

This signal is referenced to **SIGNAL RTN**.

### SYNC IN

The **SYNC IN** signal is used to allow the power supply frequency to sync with the system frequency. The system frequency should be 250kHz  $\pm$ 10kHz.

When not connected the power supply will work at 250kHz  $\pm$ 10kHz. This signal is referenced to **SIGNAL RTN**.

### SIGNAL RTN

Both **INHIBIT** and **SYNC IN** signals are referenced to this pin. This pin is floating from both input and output.

### SENSE

The **SENSE** line is used to achieve accurate voltage regulation at load terminals. To use this feature, connect this pin directly to load's positive terminal.

If this function is not required, short **SENSE** pin to **OUT** pins as close as possible to the unit.

### SENSE RTN

The **SENSE RTN** line is used to achieve accurate voltage regulation at load terminals. To use this feature, connect this pin directly to load's negative terminal.

If this function is not required, short **SENSE RTN** pin to **OUT RTN** pins as close as possible to the unit.

When not used, connect **SENSE** to **OUT** and **SENSE RTN** to **OUT RTN**

*Typical Connection Diagram*

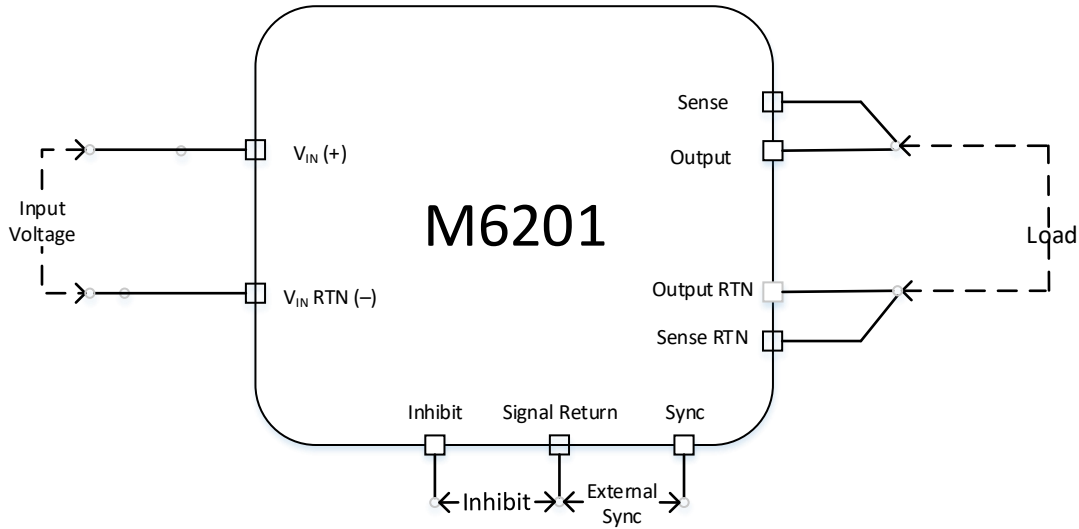

*Outline Drawing*

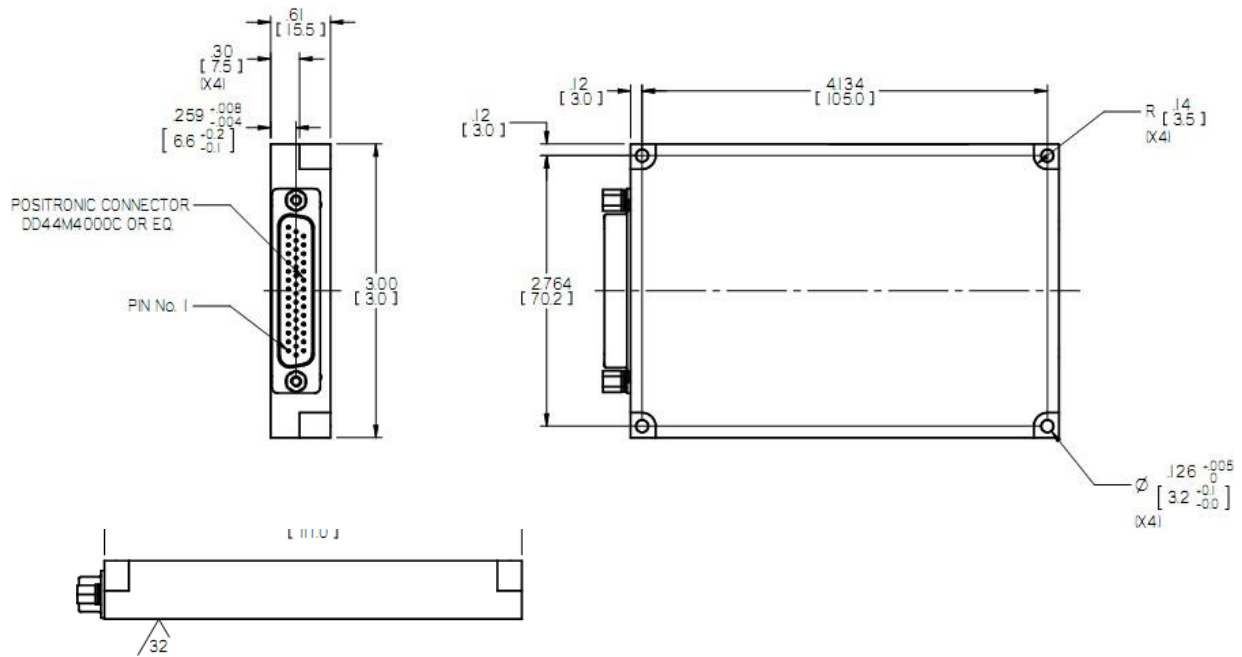

*Heat Dissipation Surface*

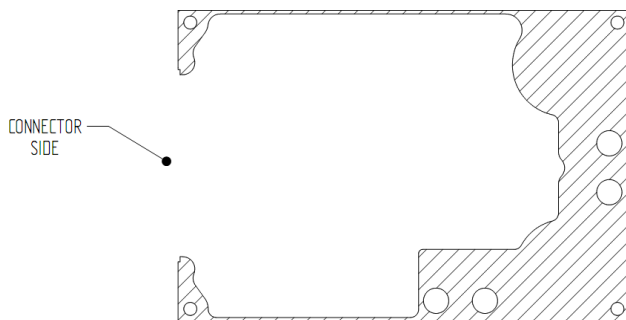

Dissipation Area 3.6534 in<sup>2</sup> [2357 mm<sup>2</sup>]

**Notes**

1. Dimensions are in inches
2. Tolerance is:  
.XX ± 0.01 in  
.XXX ± 0.005 in
3. Weight: 8.11 oz (230 g)

*Note: Specifications are subject to change without prior notice by the manufacturer.*