

# M359-3 SERIES

## UNINTERRUPTIBLE POWER SUPPLY



### PRODUCT HIGHLIGHTS

- FULL COMPLIANCE WITH MIL-STD-1399 (SECTION 300B)
- 3U RACKMOUNT
- 2.0KW/2.5KVA UPS
- 10-MINUTES HOLDUP TIME @ 1.5KW

# M359-3

## 2.0KW/2.5KVA, 3-Phase-In, 1- Phase Out UPS for Shipboard Application

**Rugged, 19" Rackmount, high performance On-Line UPS, designed for Naval Shipboard and tough industrial applications. It accepts 115VAC/60Hz, 3-Phase (Delta) Shipboard Power and provides an uninterruptable and isolated 115VAC/60Hz Single- phase output.**

### M359-3 Main Features:

- 19" Rack-mount, 3U high and 22" deep.
- A front panel loaded, Plug-in Battery Pack.
- Internal 3-phase, 60Hz Input Isolation Transformer.
- Full Compliance with MIL-STD-1399, Section 300B, Type I Power (115VAC/60Hz).
- Very low Input Current Harmonic content (MIL-STD-1399 compliant).
- Better than 98% Input Power Factor.
- Full galvanic isolation between Input, Chassis GND and Output.
- 115VAC/60Hz, low-distortion sine-wave output, synthesized from a crystal oscillator.
- Over-load, Over-voltage and Over-temperature Protection.
- Immune to MIL-STD-1399, Section 300B 1,000V spikes.
- Complies with MIL-STD-461F.
- Complies with MIL-S-901D (Grade A, Class I &2) and MIL-STD-167-1 (Type I).
- Remote Panel ON/OFF capability.
- Standard Mil-type (metal-shell) circular power connectors.
- RS-232 or Ethernet SNMP v1, v2 or v3 Control and Monitor.
- J-STD-001B and IPC-610A Class-3 Workmanship.
- MIL-I-46058C and IPC-CC-830 Polyurethane conformal coating on PWBs.

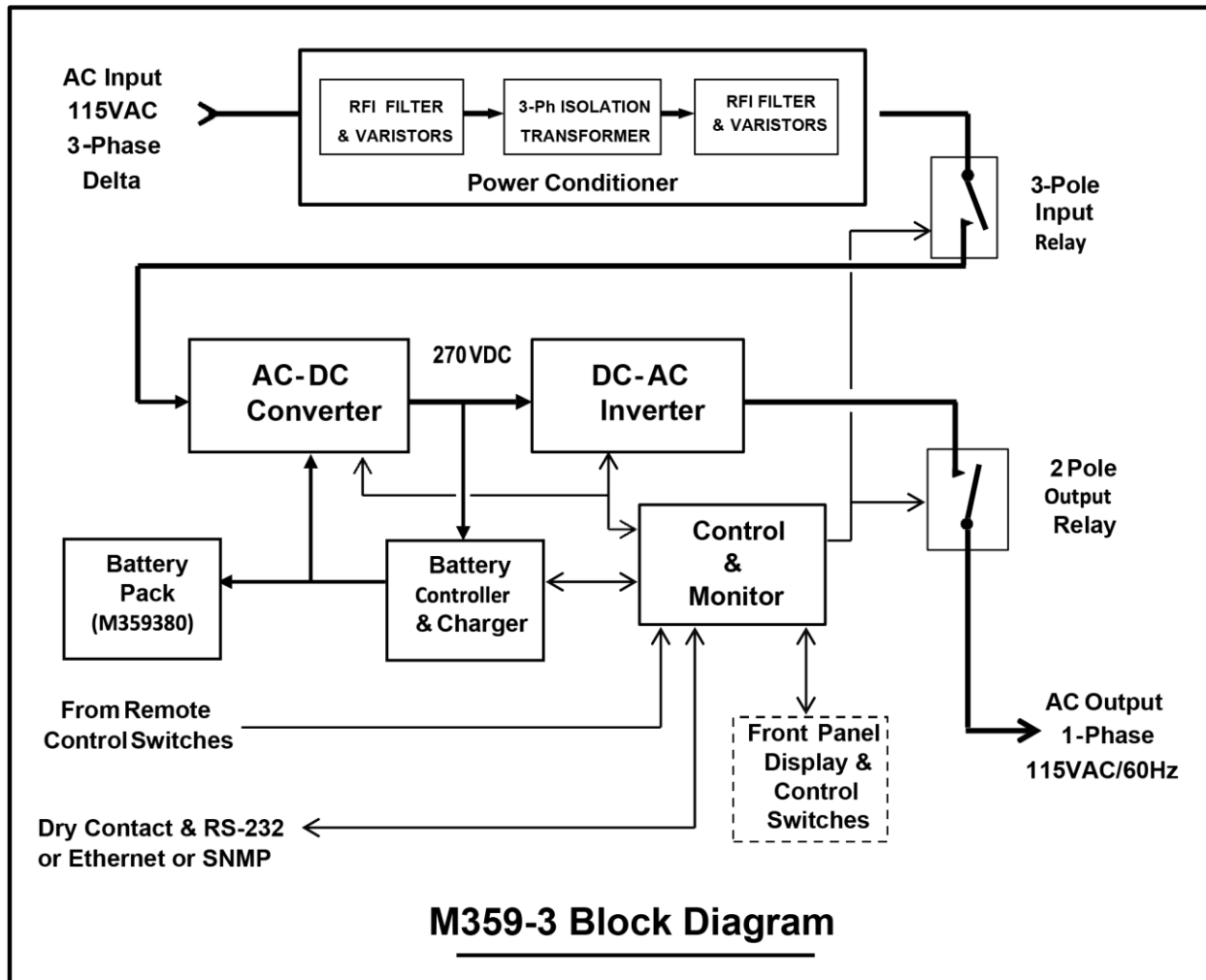

## Specification

INPUT	<b>Type</b>	115VAC/60Hz, 3-Phase Delta, Type I per MIL-STD-1399, Section 300B.
	<b>Voltage Range</b>	0 - 155VAC (L-L), in accordance with MIL-STD-1399, Section 300B.
	<b>Switchover Voltage</b>	Below 103VAC(L-L) the M359 may switch to Battery power. (92VAC @1,800W)
	<b>Frequency</b>	48-64 Hz
	<b>Power Factor &amp; Efficiency</b>	P.F: > 0.98 @ full-load. Efficiency (full-load) is higher than 84%
	<b>Spikes</b>	Withstands the 1,000V Spikes specified by MIL-STD-1399, Section 300B.
	<b>Isolation</b>	Compatible with Ungrounded Shipboard Power. AC Input is isolated from AC Output and chassis (> 10 M Ohm at 600VDC). Less than 0.02μF from each AC Input line to Chassis. Less than 2mA leakage to chassis.
	<b>Current Harmonic Distortion</b>	Less than 2.5% from 2 <sup>nd</sup> to 32 <sup>nd</sup> harmonics and less than 100%/N for harmonics between 32 <sup>nd</sup> and 20kHz (I.A.W. MIL-STD-1399, Section 300B).
	<b>Inrush Current</b>	Limited Per MIL-STD-1399, Section 300B, (less than 50A RMS).
	<b>Input Current</b>	Less than 16Amp (per phase) when loaded by 1,800W. Internally Limited to 20 Amp per Phase during over-load condition
<b>Power Interrupts</b>	No damage and no Output interrupt for all conditions of MIL-STD-1399 (300B)	
OUTPUT	<b>Voltage</b>	Single-phase, 115 ±3VAC, Grounded Neutral (Note 1).
	<b>Frequency</b>	60Hz ± 0.2% (digitally synthesized from a crystal oscillator)
	<b>Power Rating</b>	2.0KW/2.5KVA up to +45°C. 1.8KW/2.25KVA up to +55°C (Note 2).
	<b>Waveform</b>	Sinusoidal, THD of 2% (linear load), 6% (non-linear)
	<b>Over-voltage Protection</b>	Automatic shutdown if output voltage exceeds 125Vrms
	<b>Overload Protection &amp; Current Limit</b>	Output protected from overload/short-circuit condition with automatic recovery upon overload removal. Output current is Internally limited to 40 Amp peak.
BATTERY	<b>Type</b>	A Front Panel Loaded, Hot-swap Plug-in, encapsulated Battery Pack (Model M359380).
	<b>Holdup Time</b>	10 minutes (minimum) into 1.5KW AC Load.
	<b>Charger</b>	Low ripple, regulated float-charger, with current limiting and temperature compensation. Fully charges the battery within 6 hours (following a full discharge at 1.5 kW).
	<b>Protection</b>	Protected from over-discharge and thermal runaway by internal protection circuit.
	<b>Monitor</b>	The batteries charge level, temperature and health are monitored by the UPS micro-controller.
EMC	<b>MIL-STD-461F</b>	CE101, CE102, CS101, CS106, CS114, CS116 RE101, RE102, RS101 and RS103.
	<b>DC Magnetic Field</b>	1600A/m (20 Oersteds) per DOD-STD-1399.

### Notes

1. The Output Neutral Grounding Link is accessible to the user and can be removed in order to allow grounding at a user selected location, or in order to obtain a floating output (not recommended).
2. At ambient temperature above 45°C, the maximum steady-state output power should be linearly derated by 20W/25VA per each °C above 45°C, down to 1.8KW/2.25KVA at 55°C. For short term loading (less than 5 minutes) no derating is required.

<b>ENVIRONMENT</b>	<b>Temperature</b>	Non-operating: -40 to +72°C (Note 3) Operating: 0 to + 55°C (see Note 2 on previous page)
	<b>Humidity</b>	Up to 100% RH per MIL-STD-810G, Method 507.5 Proc II.
	<b>Altitude</b>	Non-operating: (Air transport) 40,000 feet.
	<b>Orientation</b>	May be installed at any orientation.
	<b>Mechanical Shock</b>	High-impact shipboard shock IAW MIL-S-901D, Grade A, Class I and II.
	<b>Vibration</b>	Type I Deck Mounted vibration IAW MIL-STD-167-1. Random vibration I.A.W. MIL-STD-810D, Cat. 9, Proc. I (test condition I-3.2.11, Fig. 514.3-34)
<b>INDICATIONS &amp; CONTROLS</b>	<b>Visual Indications (Front panel)</b>	10-segment tri-color Bar Graph for load level display. 10-segment Bar Graph for battery charge level display. "Output OK", "Output Fail" and "Standby" status LEDs. "Input OK" and "Input Fail" status LEDs. "On Batt " status LED. "Batt Passed" and "Batt Failed" LEDs for battery self-test. "Low Batt" warning LED. "Overload Shutdown" status LED. "Overtemp warning" and "Overtemp Shutdown" LEDs.
	<b>Test Mode</b>	When Battery-operation Test is invoked, the UPS performs a UPS and battery-test without interrupting the output power (even if the battery fails).
	<b>Audible Alarm</b>	The UPS beeps when operating on battery power or during over-temperature condition. The alarm may be silenced by pressing the "Alarm Off" push-button on the front panel.
	<b>Power Switches</b>	The M359 has two power relays controlled by the Front-panel switches; a 3-pole relay on the input and a 2-pole relay on the output.
	<b>Remote Control</b>	Supports a remote On/Off control by a low-power (28Vdc/0.5A) remotely located control switch.

**Notes**

1. Storing the UPS with the Battery Pack at high temperature for prolonged duration will shorten the battery life.

## M359-3 SHIPBOARD UPS

<b>INTERFACE</b>	<b>Discrete interface</b>	<p>Four dry contacts indicating the following conditions:</p> <p>"UPS ON" (Output OK)          "Battery Voltage Low"          "Input Power Loss" (Battery Operation)          "Fault Detect"</p> <p>A "Battery-saving Shutdown" input (via opto-isolator) allows the user to shut down the UPS during Battery-operation. When the AC input recovers the UPS will automatically turn ON.</p>
	<b>Ethernet SNMP Port</b>	<p>RJ-45, CAT-5 SNMP v1, v2 or v3 Port with Server/ Client Monitor Software. Allows monitoring of the UPS (using MIBs). Supports user defined event-triggered shutdown. Supports different shutdown timing for each Client in the net. Supports delayed (after Server shutdown) UPS shutdown.</p>
	<b>SerialInterface</b>	<p>Optional (instead of Ethernet) RS-232 Serial port provides Status messages, accepts User's commands and allows the setting of User-Programmable Options.</p> <p><b>RS-232 Status message:</b> Input OK, Output OK, On Battery, Low Battery, Over-Temperature Warning, Battery Test Passed/Failed, Load Level, Battery Charge Level, status of all User Programmable Options and Failure diagnostic.</p> <p><b>RS-232 Commands:</b> UPS Shutdown, UPS Standby, Initiate Battery Test, Enable/Disable Periodic Battery Test, Enable/Disable Battle Mode, Enable/Disable Audible Alarm, Protection Reset (resets all latching protection circuits), System Reset (forces all User Programmable Options into their default state and resets all latching protection circuits).</p> <p>For the complete set of the available Status messages and Commands, refer to the "UPS_Soft_1" Software Interface Manual. (Available at <a href="http://www.milpower.com">http://www.milpower.com</a>).</p>
<b>MTBF</b>		150,000 hours (at typical below-deck Naval environment)
<b>SCREENING</b>		Available upon request.
<b>ACOUSTIC NOISE</b>		Less than 54dBA (measured 3 ft from Front Panel, under normal operating conditions).
<b>FUNGUS</b>		Does not support fungus growth, in accordance with MIL-STD-810G, Method 508-6.
<b>WEIGHT and SIZE</b>		137 Pounds. (85 Pounds without the Battery Pack.) 19", 3-U, 22" deep, Rack mount or Hard mount.

How to Order

**Order P/N: M359-3 -0 -1 -0 -0 -**

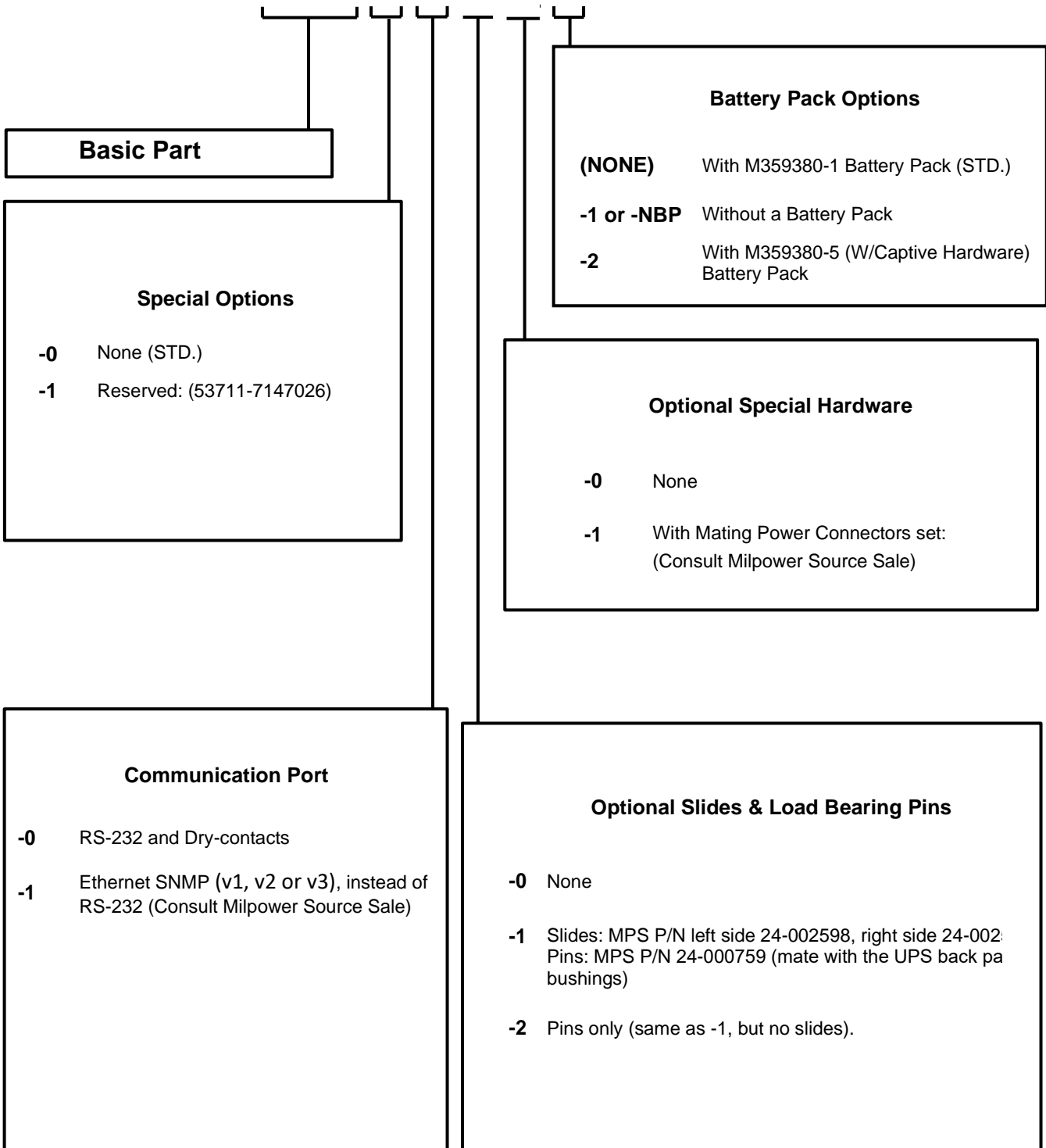

*Note: Specifications are subject to change without prior notice by the manufacturer.*