

M359-1

UNINTERRUPTIBLE POWER SUPPLY



PRODUCT HIGHLIGHTS

- FULL COMPLIANCE WITH MIL-STD-1399 (SECTION 300B)
- 3U RACKMOUNT
- 2.0KW/2.5KVA UPS
- 10-MINUTES HOLDUP TIME @ 1.5KW

M359-1 2.0KW/2.5KVA UPS for Shipboard Application

Ruggedized, high performance On-Line UPS designed for Naval Shipboard and tough industrial applications.

M359-1 Main Features:

- Full Compliance with MIL-STD-1399 (Section 300B), Type I Power (115VAC/60Hz).
- Internal Input Isolation Transformer.
- A front panel loaded, Plug-in Battery Pack.
- 10 minutes Holdup-time at 1.5KW.
- Real sine-wave 115VAC/60Hz output, synthesized from a crystal oscillator.
- Very low Input Current Harmonic content (MIL-STD-1399 compliant).
- Better than 98% Input Power Factor.
- Very low input-to-chassis capacitance (MIL-STD-1399 compliant).
- Full galvanic isolation between Input, Chassis GND and Output.
- 1000V / 50 μ s spike capability (MIL-STD-1399 compliant).
- Complies with MIL-STD-461F.
- Complies with MIL-S-901D (Grade A, Class I &2) and MIL-STD-167-1 (Type I).
- Remote Panel ON/OFF capability.
- By-pass mode, via internal Power Conditioner, Isolation Transformer and Relays.
- MS Power Connectors.
- RS-232 or Ethernet SNMP v1, v2 or v3 Control and Monitor.
- J-STD-001B and IPC-610A Class-3 Workmanship.
- Conformal Coating of PWBs per MIL-I-46058C and IPC-CC-830.

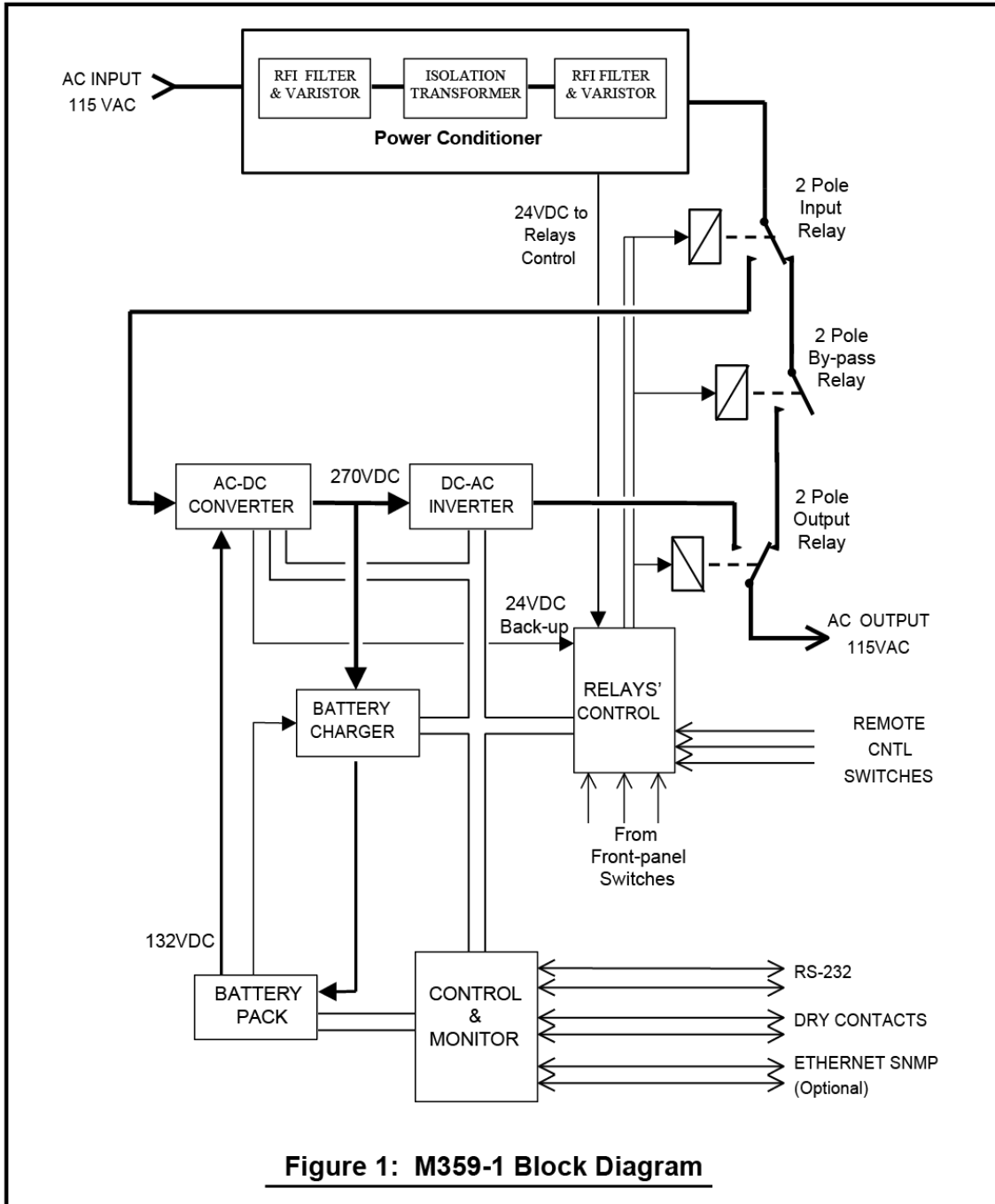

Figure 1: M359-1 Block Diagram

Specification

INPUT	Voltage Range	0 - 155VAC In Accordance with MIL-STD-1399 (Navy)
	Switchover Voltage	<102VAC, below this voltage the M359 may switch to Battery power. (Note: MIL-STD-1399 worst-case min. steady state voltage is 107VAC.)
	Frequency	48-64 Hz
	Power Factor	> 98%
	Spikes	200 joules clamping device I.A.W. MIL-STD-1399 (Navy)
	Isolation	Input is galvanically isolated from output and chassis (> 1 MΩ at 600VDC). Total capacitance between input and chassis is less than 0.02uf per line. Leakage current is less than 2ma. (130dB Input Isolation Transformer.) Both input wires may be "hot" I.A.W. MIL-STD-1399.
	Current waveform	Sinusoidal with harmonic content of less than 2.5% for harmonics between 2f ₀ to 32f ₀ and less than 100%/N for harmonics between N=32 and 20kHz. (I.A.W. MIL-STD-1399)
	Line impedance	Up to 5 ohms between 100 to 200kHz (I.A.W. MIL-STD-1399)
OUTPUT	Voltage	115Vac ± 3%, grounded Neutral (Note 1).
	Power Rating	2.0KW (2.5KVA) Continues, up to ambient temperature of +40°C. Derate linearly to 1.5KW at +52°C (ambient), (Note 2).
	Frequency	60Hz ± 0.2% (digitally synthesized from a crystal oscillator)
	Waveform	Sinusoidal , THD of 2% (linear load), 6% (non-linear)
BATTERY	Type	Front Panel Loaded, Hot-swap Plug-in, encapsulated, sealed, maintenance-free, lead-acid, Battery Pack.
	Capacity	2KW for at least 5 minutes. 1.5KW for at least 10 minutes.
	Charger	Low ripple, regulated voltage, float-charger, with current limiting and temperature compensation. Fully charges the battery within 6 hours (following 5-min. discharge at 2.0 kW).
	Protection	Battery is protected from over-discharge and thermal runaway by internal protection circuit.
	Monitor	The Battery charge level and internal impedance are monitored by the UPS micro-controller.
EMC	RFI	MIL-STD-461F Requirements: RE101, RE102, CE101, CE102, CS101, CS116 (AC Input) and RS103.
	ESD	All I/O lines are protected from ESD.

M359-1 SHIPBOARD UPS

ENVIRONMENT	Temperature	Non operating: -40 to +72°C (Note 3) Operating: 0 to + 52°C (Note 2)
	Humidity	Up to 95%, non-condensing.
	Altitude	Operating: Up to 10,000 feet. Non-operating: (Air transport) 40,000 feet.
	Orientation	May be installed at any orientation.
	Mechanical Shock	When packed, withstands the free fall drop and edgewise drop IAW Methods 5007.1 and 5008.1 of Federal Test Method standard 101C. When operating, withstands the high-impact shipboard shock IAW MIL-S-901D, Grade A, Class I and II.
	Vibration	Type I vibration IAW MIL-STD-167-1. Random vibration IAW MIL-STD-810D, Cat. 9, Proc. I (test condition I-3.2.11, Fig. 514.3-34)
INDICATIONS & CONTROLS	Visual Indications (Front panel)	10-segment tri-color Bar Graph for load level display. 10-segment Bar Graph for battery charge level display. "Output OK", "Output Fail" and "Standby" status lamps. "Input OK" and "Input Fail" status lamps. "On Batt " status lamp. "Batt Passed" and "Batt Failed" lamps for battery self-test. "Low Batt" warning lamp. "Overload Shutdown" status lamp. "Overtemp warning" and "Overtemp Shutdown" lamps.
	Test Mode	When test mode is invoked by pressing the push-button on the front panel, the UPS performs battery impedance testing without interrupting the output power (even if the battery fails) utilizing a proprietary time-sharing circuit. The test results are displayed on the panel indicators. End-to-End testing of the UPS is accomplished by cycling the INPUT UPS/BY- PASS switch on the front panel.
	Audible Alarm	The UPS will beep when it operates on battery power or during over- temperature condition. The alarm may be silenced by pressing the "Alarm Off" push-button on the front panel.
	Power Switches	The M359 has three double-pole power relays, one on the input, one on the output and a third relay that bypasses the UPS section. The front panel switches allow the user to control these three power relays.
	Remote Control	Connector J4 on the back panel, allows the controlling of the M359 by a remote 28Vdc/0.25A single pole, On/Off switch (Remote Power On/Off) and a 28Vdc/0.25A, ON-ON, single pole switch (Remote UPS/By-Pass Select).

<p>INTERFACE</p>	<p><i>Discrete interface</i></p>	<p>Four dry contacts indicating the following conditions: "UPS ON" (Output OK) "Battery Voltage Low" "Input Power Loss" (Battery Operation) "Fault Detect" A "Shutdown" input (via opto-isolator) for remote shutdown of the UPS during AC input fail. When the AC input recovers the UPS will automatically turn ON.</p>
	<p><i>Serial Interface</i></p>	<p>RS-232 Serial port (EIA-RS-232). The serial port allows transmission of status and reception of User-Programmable Options, some of which are described below: <u>Status:</u> Input OK, Output OK, On Battery, Low Battery, Over-Temperature Warning, Battery Test Passed/Failed, Load Level, Charge Level, status of all User Programmable Options and failure diagnostic. <u>Commands:</u> UPS Shutdown, UPS Standby, Initiate Battery Test, Enable/Disable Periodic Battery Test, Enable/Disable Battle Mode, Enable/Disable Aural Alarm, Set Input power Limit (see Note 2), Protection Reset (resets all latching protection circuits), System Reset (forces all User Programmable Options into their default state and resets all latching protection circuits).</p> <p>For the complete set of the available Status messages and Commands, refer to the UPS_Soft_1 Software Interface Manual. (Available at http://www.milpower.com).</p>
	<p><i>Ethernet SNMP Port</i></p>	<p>Optional, RJ-45, CAT-5 SNMP v1, v2 or v3 Port with Server/ Client Monitor Software. Allows monitoring of the UPS (using MIBs). Supports user defined event-triggered shutdown. Supports different shutdown timing for each Client in the net. Supports delay UPS shutdown (after the Server has been shutdown).</p>
<p>SCREENING</p>		<p>Each unit is subjected to a Power Burn-in of 24 hours. Additional ESS is available upon request.</p>
<p>ACOUSTIC NOISE</p>		<p>Less than 48dBA.</p>
<p>FUNGUS</p>		<p>Does not support fungus growth, in accordance with the guidelines of MIL-STD-454, Requirement 4.</p>
<p>WEIGHT and SIZE</p>		<p>140 Pounds. (88 Pounds without the Battery Pack. Add 8 pounds for M359-1-2) 19", 3-U, 22" deep, Rack mount or Hard mount.</p>

Notes

1. The Neutral Grounding Link is accessible to the user and may be removed to obtain a floating output (not recommended, may result in a safety hazard).
2. The long-term maximum loading of the UPS Output is limited by the fan's cooling capacity. At ambient temperature above 40°C, the maximum steady-state output power should be derated to 1.5KW at 52°C. For short term loading (less than 5 minutes) no derating is required.
3. High temperature for prolonged duration will shorten the battery life.

How to Order

Order P/N: M359-1 -0 -0 -0 -0

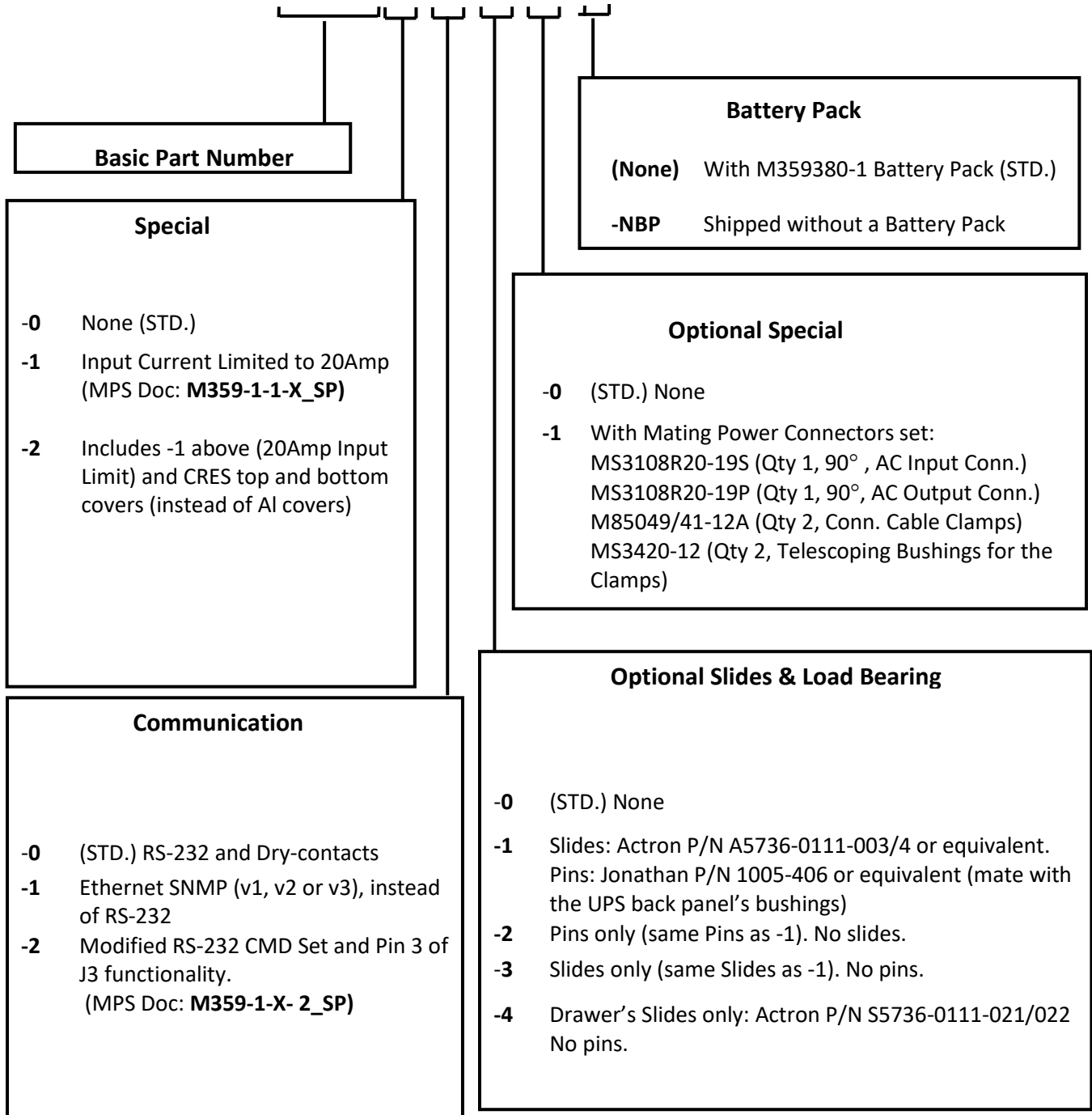

Note: Specifications are subject to change without prior notice by the